



# Installation & User Manual

## HAULWAY<sup>®</sup> Battery Pack



1-YEAR WARRANTY. Please register at [www.ezaccess.com/warranty-satisfaction](http://www.ezaccess.com/warranty-satisfaction).  
© Homecare Products, Inc. All rights reserved. All text and images contained in this document are proprietary and may not be shared, modified, distributed, reproduced, or reused without the express written permission of EZ-ACCESS®, a division of Homecare Products, Inc.



Manufactured in the USA



16606 REV 01-24-16







# **TABLE OF CONTENTS**

INTRODUCTION & IMPORTANT INFORMATION.....	3
SYMBOL MEANINGS.....	3
WARNINGS! .....	3
TOOLS TYPICALLY NEEDED.....	4
SHIPPING CONTENTS AND UNPACKING THE BATTERY PACK.....	4
INSTALLING BATTERY TRAY AND BATTERY PACK.....	5
USING THE BATTERY PACK .....	6
CHARGING THE BATTERY PACK .....	6
UNDERSTANDING BATTERY PACK LED INDICATORS .....	7
TEST HAULWAY FUNCTIONS .....	7



# HAULWAY<sup>®</sup> Battery Pack Installation & User Manual

## INTRODUCTION & IMPORTANT INFORMATION









Congratulations on your purchase of the HAULWAY<sup>®</sup> Battery Pack. The Battery Pack is a convenient, self-contained, rechargeable, take-along power supply and if used, you do **not** need to install wiring to the vehicle's battery.

-  For additional installation and operation information, please call 1-800-451-1903. To obtain additional copy of instructions, please visit [www.ezaccess.com](http://www.ezaccess.com).
-  Throughout this manual, the HAULWAY Battery Pack may be referred to as the "HAULWAY Battery Pack" or the "Battery Pack".
-  The Battery Pack fits on all HAULWAY products.
-  Under typical conditions, a properly charged HAULWAY Battery Pack supplies enough power to cycle (raise and lower) the HAULWAY several times without recharging.
-  Cold weather conditions can decrease the cycle times of the Battery Pack, and more frequent charging may be required.
-  The Battery Pack will cease to function if the battery charge becomes too low. It is important to always keep it charged.

## SYMBOL MEANINGS

-  The **WARNING** symbol indicates a potentially hazardous condition/situation. The safety warnings throughout this manual, and on your equipment, if any, are for the protection of people and property. Failure by any operator to abide by safety warnings will result in a waiver of all liabilities, loss of your warranty, and could result in equipment damage and or failure, property damage, risk of serious bodily injury, and or death. The symbol may appear in various colors and in conjunction with other symbols.
-  The **NOTE** symbol indicates important information. Failure to obey all notes could result in improper operation, less-than-optimum equipment performance, and at the sole discretion of the equipment manufacturer, may void your warranty. The symbol may appear in various colors and in conjunction with other symbols.

## WARNINGS!

-  Prior to use, read, understand, and follows all labels, installation instructions, and warnings!
-  Disconnect the vehicle battery before you begin installation.
-  Professional installation is recommended.
-  The HAULWAY Battery Pack will cease to function if the battery charge becomes too low. It is important to always keep it charged.
-  If at any time during installation or use, you feel unsure about what to do, stop and call your HAULWAY dealer for assistance, or call 800-451-1903.
-  Use HAULWAY Battery Pack only with a qualified helper.
-  Check and confirm that the HAULWAY Battery Pack is charged and functioning properly before each use.
-  Before each use, inspect the HAULWAY Battery Pack for damage, loose fitting fasteners, straps, and wires. If any such items are noted, **DO NOT USE** the HAULWAY<sup>™</sup> Battery Pack and contact your dealer right away.
-  From time-to-time, the manufacturer may provide retrofit kits and or important products information for our HAULWAY Battery Pack. By using the HAULWAY Battery Pack you agree to install any such retrofit kits/components, as the manufacture deems necessary for this product.

## TOOLS TYPICALLY NEEDED

- ✓  $\frac{1}{2}$ " wrench or socket
- ✓ Adjustable wrench

## SHIPPING CONTENTS AND UNPACKING THE BATTERY PACK

- ✎ Immediately open shipping box(es) and inspect for damage or missing parts. If damaged or missing parts are noted, DO NOT INSTALL OR USE the product. Ensure you received all components listed below (FIG 1). If you receive an incomplete delivery, please call us at 1-800-451-1903 for further instructions.

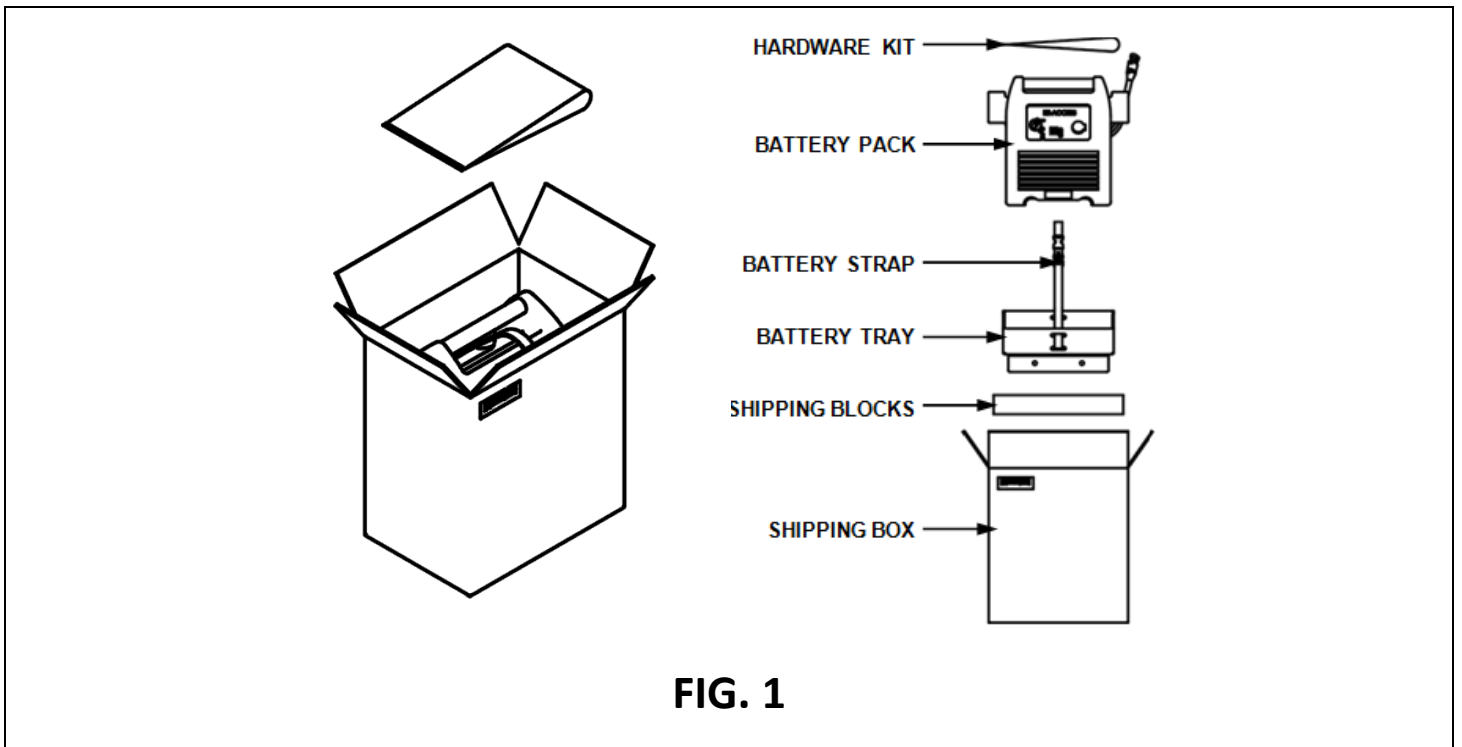

## 1. INSTALLING BATTERY TRAY AND BATTERY PACK

- 1.1. Disconnect the vehicle battery and institute reliable lock-out measures to ensure no one reconnects battery during HAULWAY installation.
  - ⚠ Always turn vehicle ignition OFF before making any Battery Pack cable connections or disconnections.
- 1.2. Slide battery tray (FIG. 2, item 1) over square tube (FIG. 2, item 2) and align bolt holes through tray and tube.
- 1.3. Slide 2 each washers (FIG. 2, item 3) over 5/16-18 cap screws (FIG. 2, item 4), and then slide cap screws through tray and tube, as shown.
- 1.4. Attach washers and nuts (FIG. 2, items 5 and 6), then tighten nuts to 28 pound-feet of torque.
- 1.5. Ensure Nylon Strap (FIG. 2, item 7) is routed through tray as shown. Move strap aside and set battery pack in battery tray.
- 1.6. Tighten strap securely and clip together (FIG. 2, item 8).
  - ⚠ Inspect and ensure the strap is tight, undamaged, and functioning properly before each use.
  - ⚠ The Battery Pack will cease to function if the battery charge becomes too low. It is important to always keep the Battery Pack charged.
  - ⚠ Over-charging batteries can result in a hazardous situation. Never over-charge batteries. Talk to your dealer for more information.
  - 👉 Under typical conditions, a properly charged Battery Pack supplies enough power to cycle (raise and lower) the HAULWAY several times. Cold weather conditions can decrease the cycle times of the Battery Pack and requires more frequent charging.

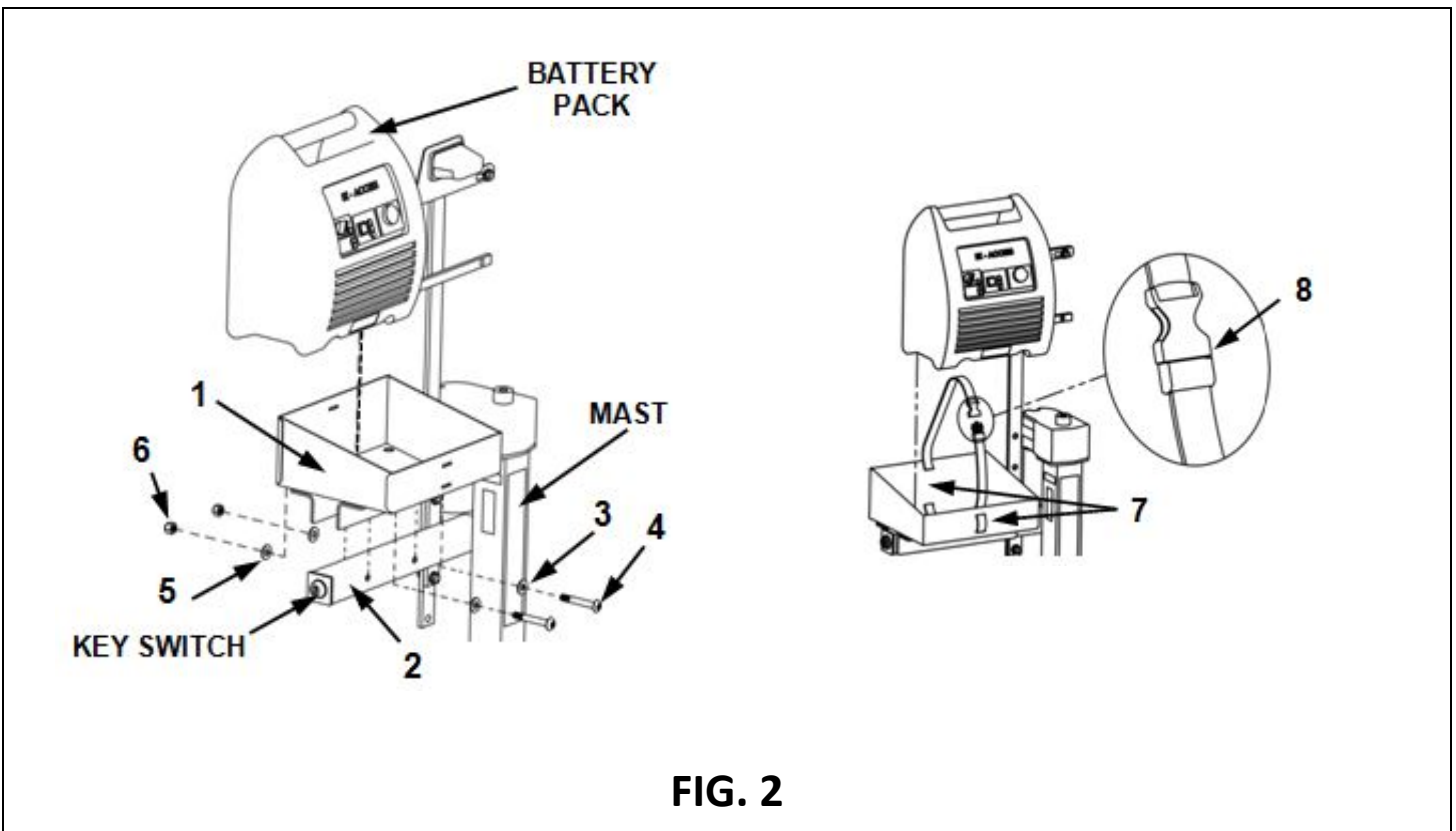

## 2. USING THE BATTERY PACK

⚠ Always turn vehicle ignition OFF before making any Battery Pack cable connections or disconnections.

- 2.1 Connect plug (FIG. 3, item 1) from Battery Pack (FIG. 3, item 2), to plug (FIG. 3, item 3) from the HAULWAY® Lift.
- 2.2 To lower the HAULWAY Lift, turn the key (FIG. 3, item 4) to the right. As the lift lowers, the platform will unfold to prepare for loading of the mobility device.
- 2.3 If motor does not have power, check all connections. If the lift still does not operate, please contact your dealer or call manufacturer at 1-800-451-1903.

✋ If platform goes in the opposite direction (up when turning the key to the right), make sure all connections are connected properly.

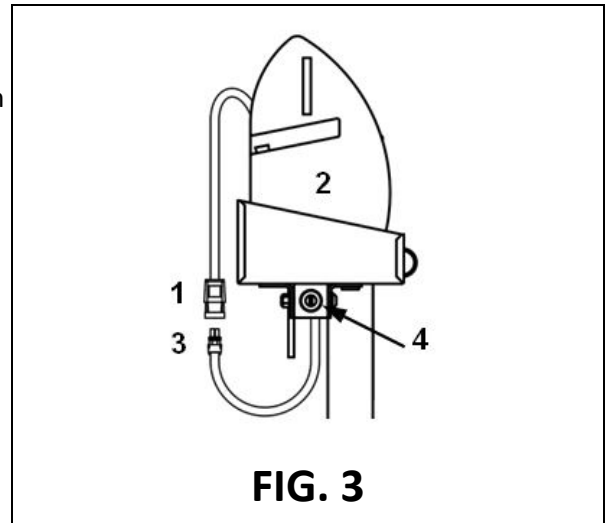

**FIG. 3**

## 3. CHARGING THE BATTERY PACK

⚠ Always turn Battery Pack ON/OFF switch to “OFF” position (FIG. 4, item 1) until all electrical connections and disconnections are made.

⚠ Always shield eyes when working with, or making connections, or disconnecting, the Battery Pack.

⚠ Because gasses can be explosive, only charge Battery Pack in a well-ventilated area.

✋ The Battery Pack has an 18-ampere hour battery; fully charged, it should provide 20-30 lift cycles.

- 3.1 Charging method 1, AC power cord:

- 3.1.1 Plug 110VAC AC power cord (FIG. 5, item 1) into back of Battery Pack (FIG. 5, item 2).

✋ 110VAC charging cable is not included.

- 3.1.2 If Battery Pack breaker (FIG. 5, item 3) trips, press it in to reset; you may need to wait a few minutes before breaker will reset.

- 3.1.3 If breaker repeatedly trips, contact your dealer or call manufacturer at 1-800-451-1903.

- 3.2 Charging method 2, DC power cord:

- 3.2.1 Plug one end of supplied 12VDC auto charger (FIG. 5, item 4) into front of the Battery Pack port (FIG. 5, item 5) and the other end into automobile’s 12VDC auxiliary supply port in the (FIG. 5, item 6).

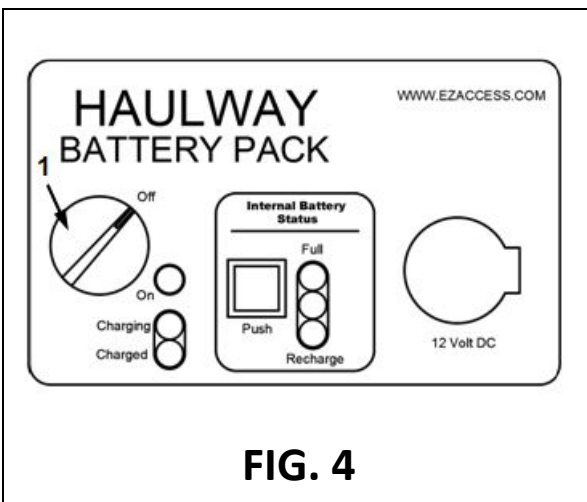

**FIG. 4**

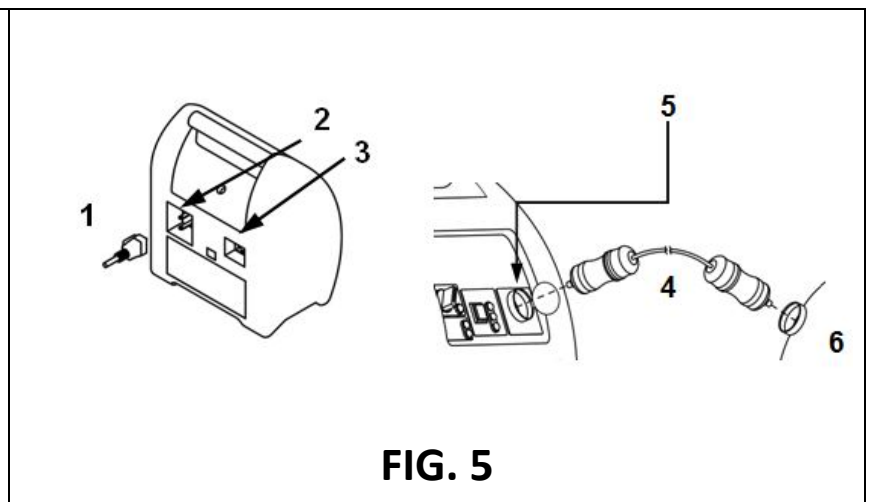

**FIG. 5**

## 4. UNDERSTANDING LED INDICATORS

- 4.1. The ON/OFF switch (FIG. 6, item 1) turns the battery power OFF and ON.
- 4.2. LEDs (FIG. 6, item 2) indicate the state of the charge
  - 4.2.1. RED = charging
  - 4.2.2. GREEN = charged
- 4.3 To check the internal battery's state-of-charge, push the Internal Battery Status (FIG 6, item 3) button and observe the LED displays:
  - 4.3.1 RED = Charging (FIG. 6, item 2) illuminates when the internal battery is charging from a 120 VAC electrical wall outlet.
    - i. Indicates a 50% or less charge; immediate recharging required.
    - ii. Continues to illuminate until battery reaches a 75% charge.
  - 4.3.2 YELLOW = Indicates a 75% or higher charge
    - iii. The Battery Pack may be used, but should be charged soon.
  - 4.3.3 GREEN = Indicates the internal battery is fully charged.

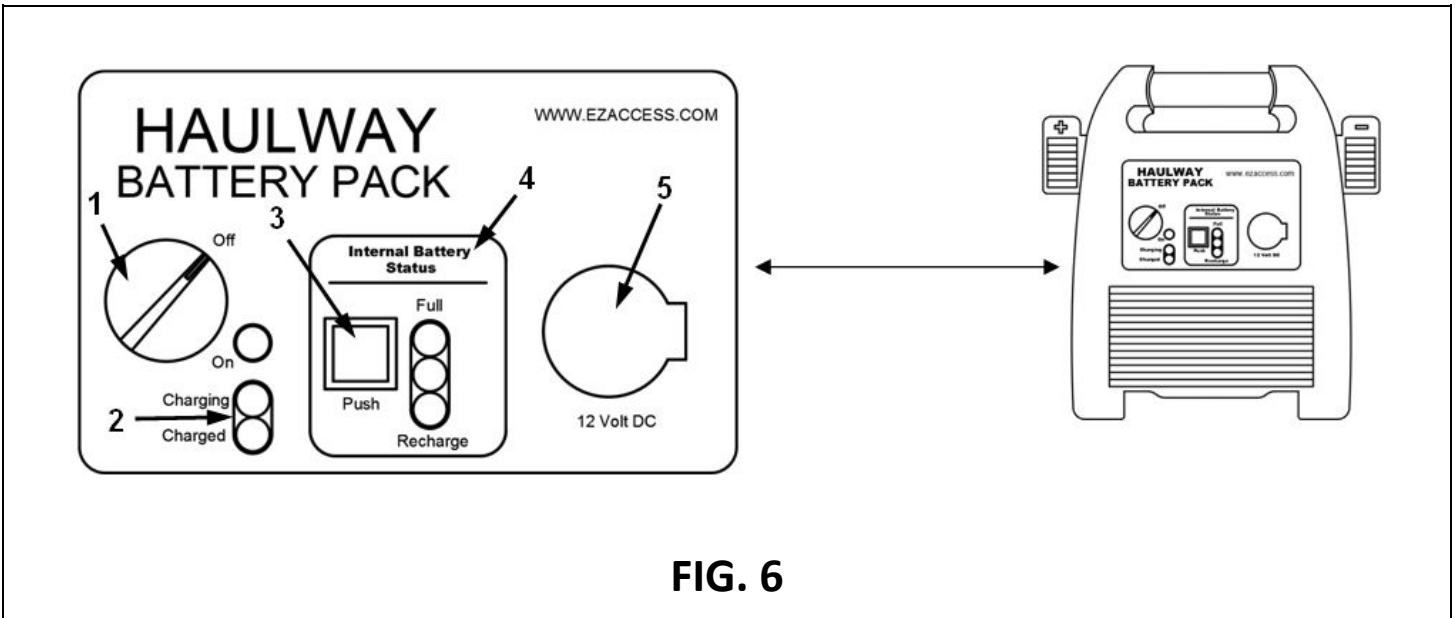

## 5. TEST HAULWAY FUNCTIONS

- 5.1. Turn HAULWAY Lift key to the right to ensure that the lift has power.
  - 👉 Turning key to the right will lower the HAULWAY Lift. As the lift lowers, it will unfold to prepare for loading of the mobility device.
  - 👉 Refer to your *HAULWAY Installation and User Manual* for lift functionality, if needed.
- 5.2. If motor does not have power, check all connections to ensure they are secure.
- 5.3. If platform goes in the opposite direction (up when turning to the right), make sure all connections are connected properly.
  - 👉 If, after following the process above, the HAULWAY Lift does not operate or have power, please go through the process a second time and look for improperly connected wiring.
  - 👉 If the HAULWAY Lift still fails to function, stop and call your HAULWAY dealer for assistance, or call 1-800-451-1903.